

PotisBank-L6.25-AC

Utility-Scale Liquid Cooling ESS

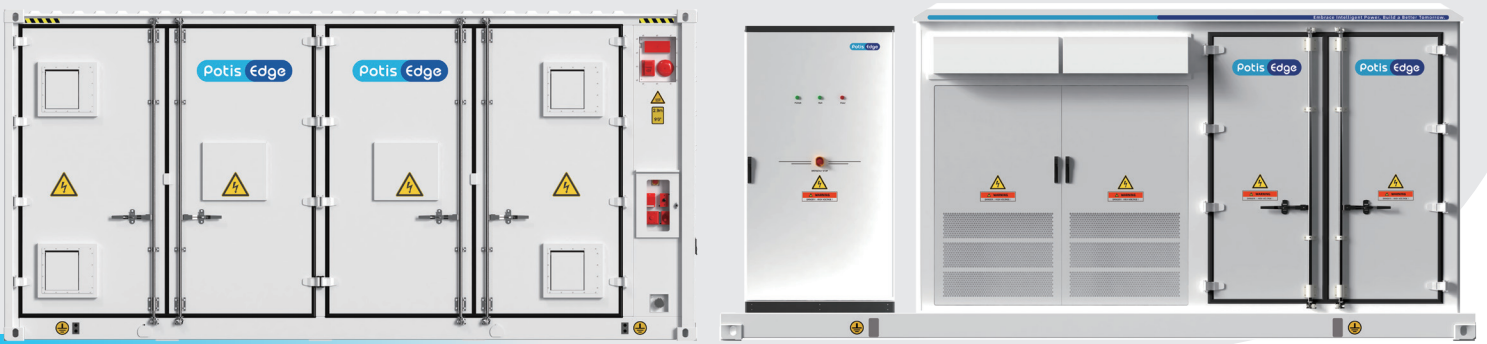

SAFE AND RELIABLE

- Multi-stage active fire detection & suppression (NFPA 855 compliant)
- Advanced liquid cooling for high thermal stability
- 3-level BMS for cell and system monitoring and protection



ECO-FRIENDLY & VERSATILE DESIGN

- RoHS, REACH compliant and cobalt-free
- Low noise, recyclable, and eco-friendly refrigerant
- Compatible with both string and central PCS



HIGH ENERGY DENSITY

- 6.25MWh per cabinet offers higher energy density
- Simplified installation and lower O&M workload
- Ideal for industrial, utility, and grid-serving applications



HIGH EFFICIENCY

- Excellent thermal management reduces auxiliary consumption
- Extended battery lifespan with high cycle life
- Support both back-to-back and side-by-side installation
- Lower LCOE (Levelized Cost of Energy)

System Diagram

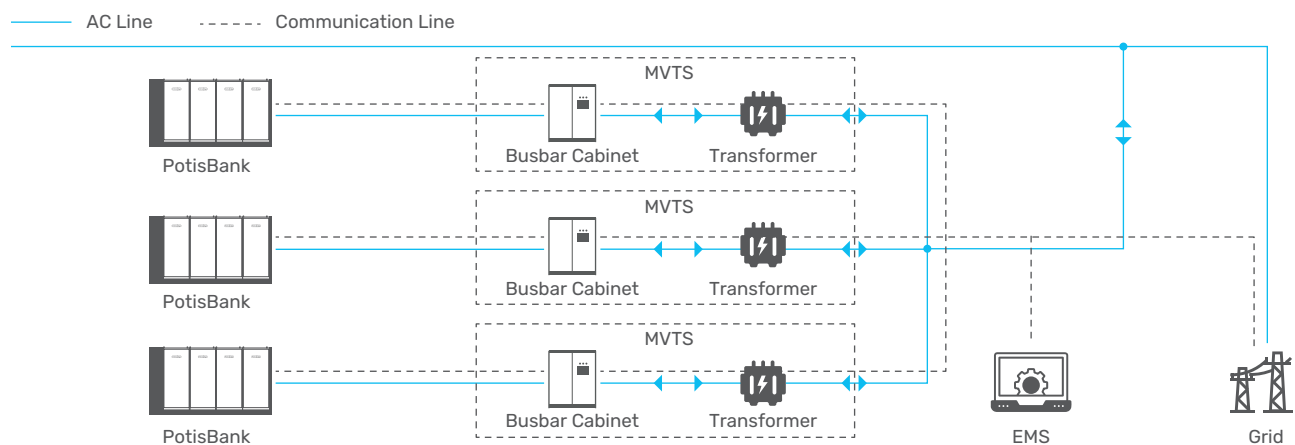

Technical Data	PotisBank-L6.25-AC-4h	PotisBank-L6.25-AC-2h
DC Side		
Cell type	LFP	
System battery configuration	416S8P	
Nominal capacity	6251kWh	
Nominal voltage	1331.2V	
Operating voltage range	1164.8~1500VDC	
AC Side		
Rated output power	215kW*8	430kW*8
Rated grid voltage	690V	
Rated grid frequency	50/60Hz	
Max. THD of current	<3%	
Power factor range	-1~+1	
General Parameter		
Dimensions(W*D*H)	6058*2438*2896mm	
Weight	≈48t	
Optional color	Standard RAL 7035	
Degree of protection	IP55 / Type 3R	
Anti-corrosion degree	C4 / C5 (optional)	
Operation humidity range	0%-95%, RH	
Operation temperature range	-30~+55°C	
Max. operating altitude	2000m	
Temperature control method	Intelligent Liquid Cooling (Pack & PCS)	
Noise	≤75 db@1m	
Fire suppression system	Smoke and heat detectors, FACP, Sprinkler, Fire alarm system, Flammable Gas detector, NFPA 69, compliance ventilation system, Aerosol Fire-extinguishing System (optional), NFPA 68 compliance vent panel (optional)	
Communication interface	Ethernet	
Communication protocol	Modbus TCP, IEC61850, IEC104	
Standard & Compliance		
Standard	UL9540A, UL1973, UL9540, UL50E, NFPA855, NFPA68 (optional), NFPA69, HMA, UN 38.3 / UN 3536, IEC62619, IEC63056, IEC60529, IEC62477	

*The specifications are subject to change without prior notice.