

Specifications

Model	PotisBank-L3.7-1500
System Parameters	
Cell type	LFP
Rated Power	3727.36 kWh
Battery Rated Voltage	1331.2 V
Battery Voltage Range	1164.8 V~1500.0 V
Max. System Efficiency	94%
Charge & Discharge Rate	0.5/1 C
Cooling Method	Liquid Cooling
Max. operating altitude	≤2000 m
Operating temperature range	-40 ~ +60 °C
Relative operating humidity	0%-95%, RH
Ingress Protection	IP55
Communication Interface	Ethernet/RS485/CAN
Communication Protocol	Modbus TCP / Modbus RTU / CAN 2.0
Fire Control	Perfluorohexanone + water spray
Weight	37 t
Dimension (W*D*H)	6058*2438*2896 mm
Certifications	IEC/EN62619, IEC/EN63056, IEC/EN61000, FCC, IEC/UL60730, UL1973, UL9540A, UN38.3, IEC/EN62477, UL9540, UN3536

© The specifications are subject to change without prior notice.

Potis Edge

Utility-scale Liquid Cooling ESS

PotisBank-L3.7



📍 Building 28, No.2 Taishan Road, Suzhou New District, China

✉ sales@ipotisedge.com

☎ 400-139-1039

iPotisEdge Co., Ltd.
www.potisedge.com

High Voltage Liquid Cooling ESS

PotisBank-L3.7

With liquid cooling design, the PotisBank-L3.7 achieves rapid heat transfer and efficient system cooling effect. Meanwhile, due to the high specific heat capacity of liquid, its own temperature will not change significantly after absorbing a large amount of heat, so it can maintain a very small temperature difference. Compared with air cooling, the specific heat capacity of liquid is less susceptible to the influence of altitude and air pressure, and can maintain a high cooling efficiency. The energy consumption of the system is reduced by 20% and the battery life is extended by 10%, effectively reducing the energy consumption ratio.



Thermal Simulation Illustration

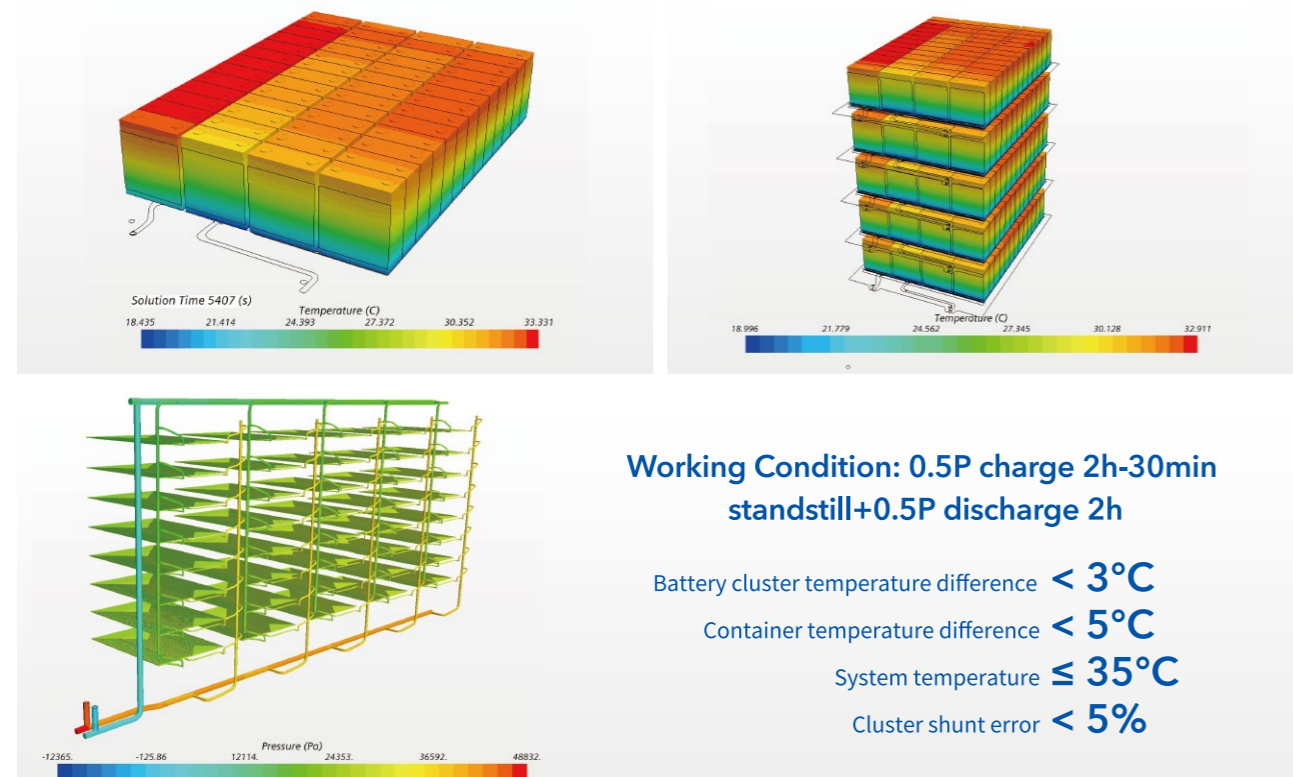

System Topology

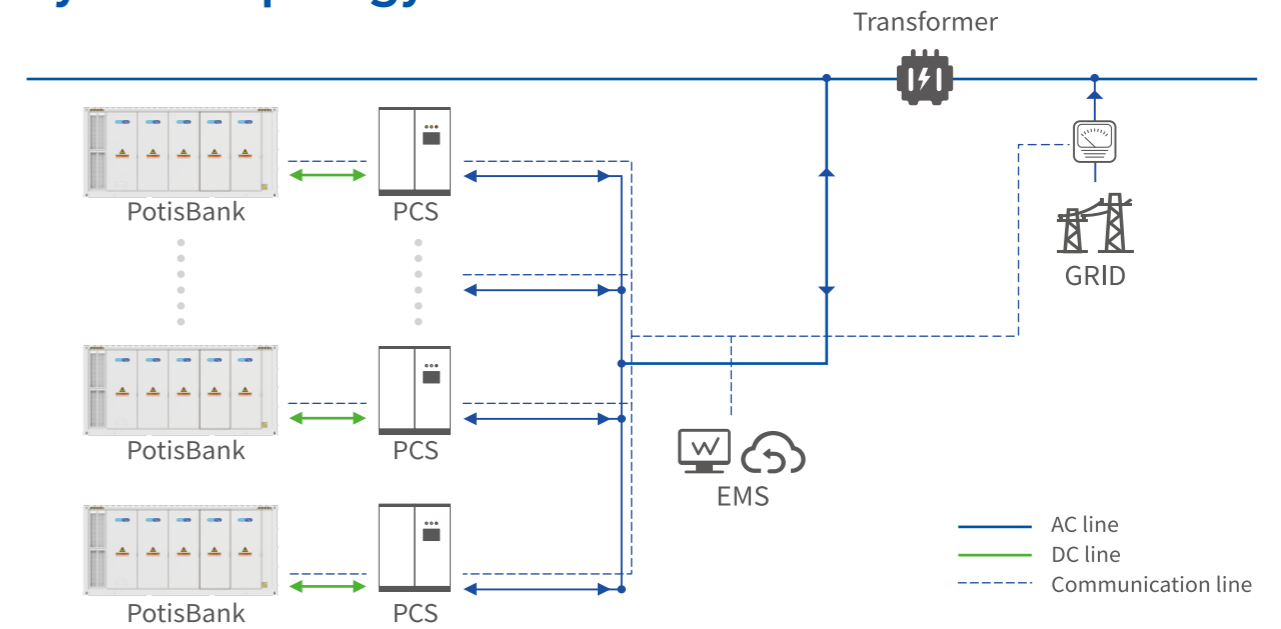

- Safe and Reliable**
Pre-assembled and tested before delivery
Automatic temperature control system
- Intelligent BMS**
Fast status monitoring and fault logging
Support early warning and fault detection
- Reliable Quality Assurance**
High standard quality control system
Quality assurance and control mechanism throughout the process
- Comprehensive Services**
One-stop localization support

Application Scenarios

